

Upper Board/Reed Switch Replacement

Tools required:

- Philips Screwdriver

Procedure:

- 1) Turn off the power to the treadmill and unplug the power cord from the wall outlet.
- 2) Remove screws connecting faceplate to console shell. (For 2001-2004 models Remove the screws from the back of the console panel. See figure 7) If not replacing reed switch skip to step 5.
- 3) **For Models T61 -T64/CST 3.5 & 4.5/DT650 & 850/WT950 Only** – Unplug and remove reed switch from small plastic knobs. (Figures 1 & 3)

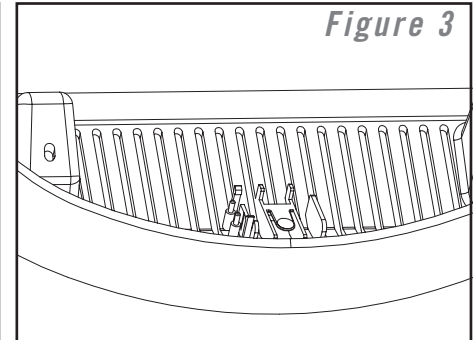
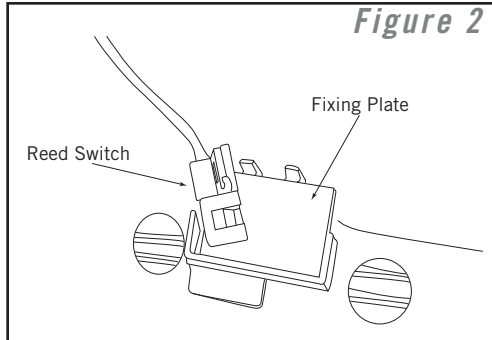
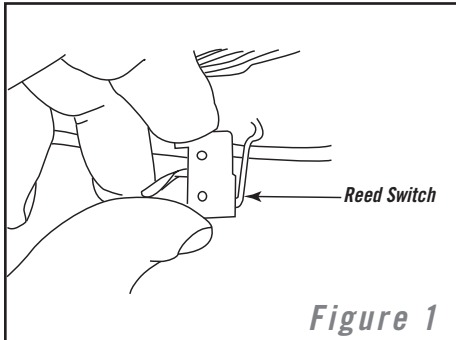

- 4) **For Models PST 6 & 8/ 1.2T-5.2T Only** – Unplug reed switch from upper board and remove switch from fixing plate. (figure 2) Skip to step 8.

You will need an adhesive when reinstalling new switch.

- 5) Unplug all the cables to the upper board.
- 6) Remove screws holding upper board to faceplate (console panel for 2001-2004 models) and replace old upper board with new one. (Figures 4, 5, 6)
- 7) Reconnect all cables to the new upper board.
- 8) Reattach the faceplate (back console panel for 2001-2004 models) and tighten all screws.
- 9) Calibrate unit with instructions. (If instructions were not included contact Horizon Fitness 800-244-4192)

